

Dual DPST JFET Analog Switch

Features

- Standby Power: <1 mW
- Bipolar Drivers
- Constant $r_{DS(on)}$ Over Signal Range
- Off Isolation: > 60 dB @ 1 MHz
- Make-Before-Break

Benefits

- Minimizes Standby Power Requirements
- Better Radiation Tolerance
- Less Distortion
- Higher Frequency Switching
- Smooth Closed Loop Response

Applications

- Battery Powered Systems
- Aerospace Control Systems
- Low Distortion Circuits
- High Frequency Switching Circuits

Description

The DG129 is a dual double-pole single-throw analog switch for use in instrumentation, control, and audio communication systems. It is ideally suited for applications requiring a constant on-resistance over the entire analog range.

On-resistance for the DG129 is 20 Ω (typical), and on-leakage is < 2 nA. With all switches off, total power consumption is < 750 μ W. These switches have make-before-break action and due to the processing are

relatively radiation tolerant. An enable pin (V_R) simplifies interfacing with microprocessor, or other logic.

Each device contains four junction field-effect transistors (JFETs) to achieve constant on-resistance. Level-shifting drivers enable low-level inputs (0.8 to 2.5 V) to control the on-off state of each switch. With logic "0" at the driver input the switches will be off. With a logic "1" at the input the switches will be on. In the on-state each switch will conduct current in either direction, and in the off-state each switch will block voltages up to 20 V peak-to-peak.

Functional Block Diagram and Pin Configuration

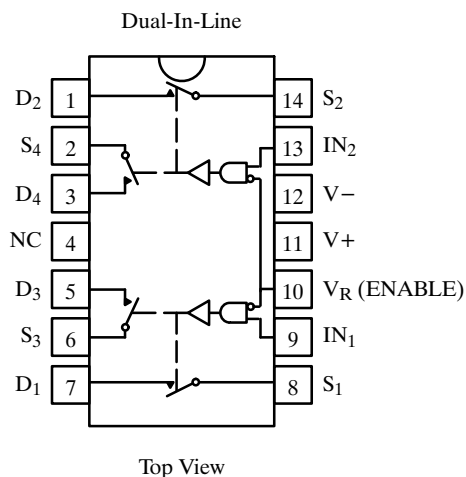

Two DPST Switches per Package

Truth Table

Logic	Switch
0	OFF
1	ON

Logic "0" \leq 0.8 V
 Logic "1" \geq 2.5 V

Switches Shown for Logic "0" Input

Ordering Information

Temp Range	Package	Part Number
-55 to 125°C	14-Pin Sidebrazed	DG129AP/883
		781401CA

DG129

Absolute Maximum Ratings

V+ to V-	36 V	Current (any terminal)	30 mA
V+ to V _D	36 V	Storage Temperature	-65 to 150°C
V _D or V _S to V-	36 V	Power Dissipationa	
V _D to V _S	±22 V	14-Pin DIP ^b	825 mW
V+ to V _R	25 V		
V _R to V-	25 V	Notes	
V _{IN} to V-	30 V	a. All leads welded or soldered to PC Board.	
V+ to V _{IN}	25 V	b. Derate 11 mW/°C above 75°C	
V _{IN} to V _R	±6 V		

Specifications^a

Parameter	Symbol	Test Conditions Unless Otherwise Specified V+ = 12 V, V- = -18 V, V _R = 0 V, V _{IN} = 0.8 V or 2.5 V ^f	Temp ^b	A Suffix -55 to 125°C			Unit
				Min ^d	Typ ^c	Max ^d	
Switch							
Analog Signal Range	V _{ANALOG}		Full	-10		10	V
Drain-Source On-Resistance	r _{DS(on)}	I _S = -10 mA, V _D = 10 V	Room Full		20	30 60	Ω
Source-Off Leakage Current	I _{S(off)}	V _S = ±10 V, V _D = ∓10 V	Room Full	-1 -100	0.03	1 100	nA
Drain-Off Leakage Current	I _{D(off)}	V _D = ±10 V, V _S = ∓10 V	Room Full	-1 -100	0.02	1 100	
Channel-On Leakage Current	I _{D(on)}	V _D = V _S = -10 V	Room Full	-2 -100	-0.03		
Input							
Input Current with Input Voltage High	I _{INH}	V _{IN} = 2.5 V	Room Full		15	60 120	μA
Input Current with Input Voltage Low	I _{INL}	V _{IN} = 0.8 V	Room Full		0.005	0.1 2	
Dynamic							
Turn-On Time	t _{ON}	See Figure 1	Room		0.5	0.6	μs
Turn-Off Time	t _{OFF}		Room		1.1	1.6	
Source-Off Capacitance	C _{S(off)}	f = 1 MHz V _D , V _S = 0	Room		2.4		pF
Drain-Off Capacitance	C _{D(off)}		Room		2.4		
Channel-On Capacitance	C _{D(on)}		Room		2.8		
Off-Isolation	OIRR	R _L = 75 Ω, f = 1 MHz	Room		> 60		dB
Supply							
Positive Supply Current	I+	One Channel On V _{IN} = 2.5 V	Room		2.5	3	mA
Negative Supply Current	I-		Room	-1.8	-1.6		
Reference Supply Current	I _R		Room	-1.4	-1.1		
Positive Supply Current	I+	All Channel Off Both V _{IN} = 0 V	Room		0.6	25	μA
Negative Supply Current	I-		Room	-25	-0.5		
Reference Supply Current	I _R		Room	-25	-0.5		

Notes

- Refer to PROCESS OPTION FLOWCHART (Section 5 of the 1994 Data Book or FaxBack number 7103).
- Room = 25°C, Full = -55 to 125°C.
- Typical values are for DESIGN AID ONLY, not guaranteed nor subject to production testing.
- The algebraic convention whereby the most negative value is a minimum and the most positive a maximum, is used in this data sheet.
- Guaranteed by design, not subject to production test.
- V_{IN} = input voltage to perform proper function.

Test Circuits

Switch output waveform shown for $V_S =$ constant with logic input waveform as shown. Note that V_S may be + or – as per switching time test circuit. V_O is the steady state output with switch on. Feedthrough via gate capacitance may result in spikes at leading and trailing edge of output waveform.

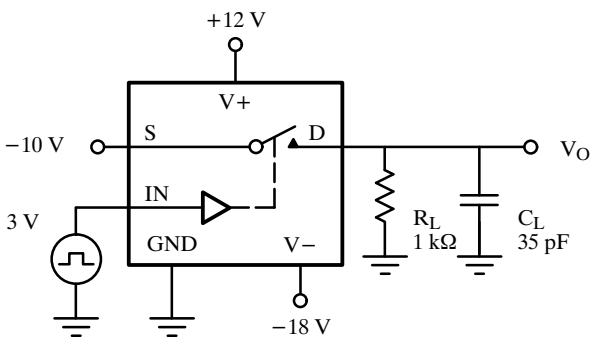

C_L (includes fixture and stray capacitance)

$$V_O = V_S \frac{R_L}{R_L + r_{DS(on)}}$$

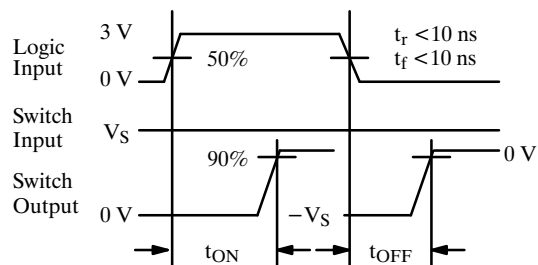

Logic "1" = Switch On

Figure 1. Switching Time

Application Hints

V+ Positive Supply Voltage (V)	V- Negative Supply Voltage (V)	VR Reference Voltage (V)	VIN Logic Input Voltage VINH(min)/VINL(max) (V)	VS or VD Analog Voltage Range (V)
12	-18	0	2.5/0.8	-10 to 10
15	-15	0	2.5/0.8	-7 to 13
7	-12	0	2.5/0.8	-5 to 5
5	-15	0	2.5/0.8	-7 to 3
5	-10	0	2.5/0.8	-2 to 3